



WATERMOT[®]

Submersible Motors

6"



nemutlu[®]

POMPA DÖKÜM MÜHENDİSLİK SAN.ve TİC. A.Ş.

www.nemutlu.com.tr

Genel Özellikler General Features المواصفات العامة

- ▶ 37 kW'a kadar sarılabilir motorlar
Rewindable motors up to 37 kW / 37 kW إلى تصل إلى
- ▶ Düşük işletme maliyeti ile yüksek verim
High efficiency provides operation cost savings / الكفاءة العالية توفير تكاليف تشغيل منخفضة
- ▶ Su ile soğutmalı sistem
Water cooling system/ نظام تبريد بالماء
- ▶ NEMA standartlarında üst flanş
Flange with NEMA standards / حافة الأنبوبة وفقاً لمعايير NEMA
- ▶ Paslanmaz çelik motor mili
Stainless steel shaft / محور المحرك من الستانلس ستيل
- ▶ Korozyona dayanıklı, direnci yüksek malzeme seçeneği (AISI 304 - AISI 316 - Duplex - Bronz)
Optional high corrosion resistive materials (AISI 304 - AISI 316 - Duplex - Bronze)
(AISI304- AISI 316- Duplex- Bronze) مواد اختيارية ذات مقومة عالية للتآكل
- ▶ Maksimum su sıcaklığı 30°C (50°C ve 70°C seçenekleri opsiyoneldir.)
Max. ambient water temperature 30°C (50°C and 70°C is optional)
الدرجة القصوى لحرارة المياه المحيطة 30 درجة مئوية (50 درجة و 70 درجة مئوية اختيارية)
- ▶ Standart voltaj 380/460V - 50/60Hz (Voltaj toleransı ±%10'dur.)
Standard voltage 380/460V - 50/60Hz (Allowable voltage tolerance ±%10.)
قيمة الفولت المعيارية 380 / 460 فولت - 50 / 60 هيرتز (تفاوت الفولت المسموح مكانيا ±%10)
- ▶ Frekans konvertörü ile istenen devirde çalıştırılabilme (30Hz üzerinde)
Variable operation revolutions by frequency convertor (over 30Hz) /
دورات التشغيل المعيارى عن طريق محول التردد (فوق 30 هيرتز)
- ▶ Soft-Starter ile kalkışa uygun motor
Availability to be operated by Soft-Starter / مناسب للعمل مع محرك Soft- Starter
- ▶ Her iki yönde çalışabilme
CW & CCW direction of rotation . / الدوران في كلا الاتجاهين
- ▶ Motorları tekrar sarılabilmesi özelliği ile (PVC, PP ve PE2+PA bobin teli) uzun yıllar hizmet verebilir.
Rewindable Motors (PVC, PP & PE2+PA winding wire) provides long service life
- توفر المحركات القابلة لللف (من أسلاك لف PVC، PP و PE2+PA) عمر أطول أثناء العمل
- ▶ Yatay çalışabilme özelliği ile havuzlarda ve derinliğin fazla olmadığı keson kuyularda yatay olarak da rahatlıkla çalışabilir.
Our motors can operate horizontally and easily in pools and in very deep wells. /
محركاتنا تعمل أفقياً فى الأحواض والآبار العميقة وبسهولة.
- ▶ Motor flanşları standart AISI 304 hassas dökümdür.
Motor flanges are standart AISI 304 precision casting.

Parça Listesi
 Part List

قائمة القطع

No	Parça Adı / Part Name	اسم القطعة	Malzeme / Material
1	Bobinli stator / Stator	الملف الثابت-	-
1.1	Sargı teli / Winding wire	سلك اللف	PVC - PP
1.2	Stator paketi / Stator package	الرزمة الثابتة	M350 / Magnetic Seal
1.3	Stator gövdesi / Stator shell	الجسم الثابت	AISI 304
2	Rotor / Rotor	الدوار	-
2.1	Yatak mil gömleği / Shaft sleeve	محور الجلبة	St 52 (crNi kaplama / Coated CrNi)
2.2	Balans halkası / Balance ring	خاتم التوازن	St 37
2.3	Bakır halka / Copper ring	حلقة نحاسية	Cu
2.4	Mekanik salmastra alt pulu / Cover seal	ختم الغطاء	St 37
3	Radyal yatak / Radial bearing	حامل شعاعي	Karbon / Carbon
4	Üst yatak gövdesi / Upper bearing body	جسم الحامل العلوي	GG20-22
5	İç bilezik / Bushing	السنارة الداخلية	Bronz / Bronze
6	Kum çanı / Slinger (sand guard)	حامي الرمال	NBR_EPDM
7	İmbus civata / Hexagon socket cap screws	مقيس مسداسي الشكل يغطي المسامير	Inox
8	Bakır rondela / Copper ring	حلقة نحاسية	Cu
9	Mekanik salmastra üst parçası / Cover seal	ختم الغطاء	AISI 420
10	Mekanik salmastra / Mechanical seal	ختم ميكانيكي	Seramik Karbon / Ceramic Carbon
11	Eksenel yatak kaması / Axial thrust bearing key	مفتاح حوامل الضغط المحوري	AISI 304
12	Eksenel karbon yatak / Axial thrust bearing	خاتم الاحتفاظ	Antimuan Karbon / Carbon With Antimony
13	Mil segmanı / Retaining ring	محور موازنة	AISI 304
14	Eksenel yatak gövdesi tespit saplaması / Tie rod	جسم الحامل السفلي	AISI 420
15	Alt yatak gövdesi / Lower bearing body	داعم حامل الضغط	GG20-22
16	Eksenel yatak taşıyıcı / Thrust bearing support	ممسك الكرة	GG20-22
17	Eksenel yatak bilya merkezleyici / Ball holder	كرة حامل الضغط	St 37 (Cr+3 kaplama / Coated Cr+3)
18	Eksenel yatak bilya / Thrust bearing ball	منصات امالة	AISI 304
19	Eksenel yatak segmenti / Tilting pads	حلقة	AISI 420
20	Eksenel yatak O-ring / O-ring	جسم حامل الضغط	NBR 70
21	Eksenel yatak gövdesi / Thrust bearing body	حلقة نحاسية	GG20
22	Bakır rondela / Copper ring	صممة ربط الجسم السفلي	Cu
23	Alt gövde saplama bağlantı somunu / Nut	جوزة	AISI 304
24	Eksenel yatak ayar civatası / Screw (thrust bearing base)	صممة معيارية في قاعدة حامل الضغط	AISI 420
25	Membran lastiği / Membrane	غشاء او خلية	NBR-EPDM
26	Membran gövdesi / Membrane body	جسم الغشاء	GG22
27	İmbus civata / Hexagon socket cap screws	مقيس مسداسي يغطي المسامير	AISI 304
28	Çekvalf / Check-valve	فحص الصمام	Bronz / Bronze
29	O-ring / O-ring	خاتم-O	NBR 70
30	Kablo çıkış lastiği / Cable seal	ختم الكبل	NBR 70
31	Kablo çıkış lastiği baskı sacı / Seal cover	غطاء الختم	AISI 304
32	Pompa motor somunu / Nut	برغي محرك الضخ	AISI 304
33	Kör tapa / Plush (r 3/8")	الطبق الاعمي	Bronz / Bronze
34	Eksenel yatak pimleri / Ball holder pins	الدبابيس حاملة الكرة	AISI 420



Teknik Çizim Technical Drawing

الرسم الفني

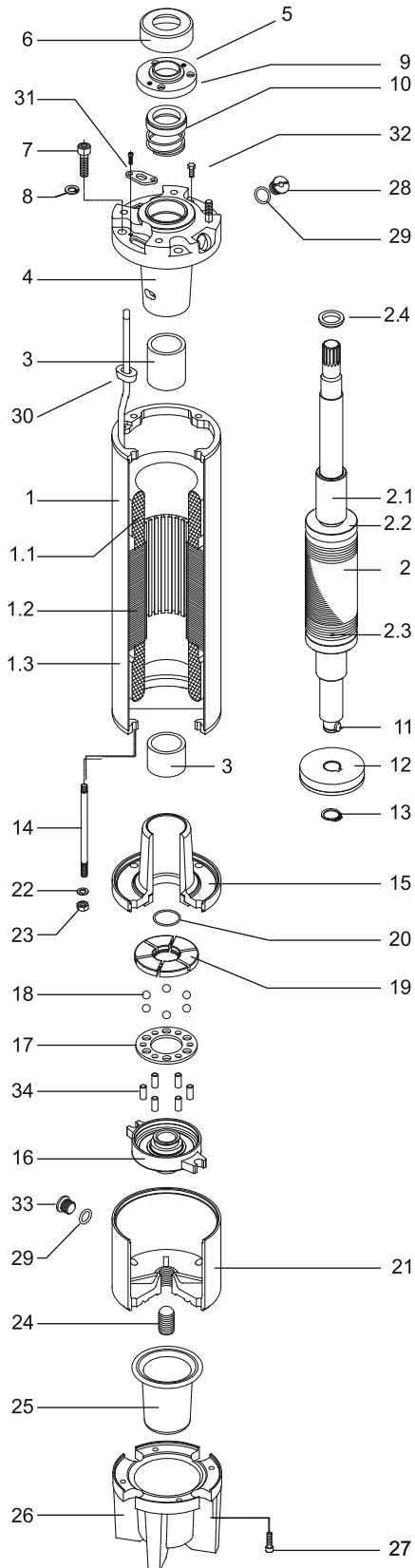



NWM 6" Dalgıç Motoru Teknik Özellikler NWM 6 "Submersible Motor Technical Specifications

Tip Type	Güç Power		Kablo Bağlantısı / Cable Connection				Eksenel Yük Axial Load	Başlangıç Yol Verme	Çap Ø max	L	Ağırlık Weight
			Direkt (D.O.L)		Y-Δ / Star-Delta						
	kW	HP	mm ²	n x mt	mm ²	n x mt	kN	start/h	mm	mm	kg
NWM 6	4	5.5	3x2,5	1 x 4	3x2,5	2 x 4	20	20	142	648	36
NWM 6	5.5	7.5	3x2,5	1 x 4	3x2,5	2 x 4	20	20	142	677	44
NWM 6	7.5	10	3x2,5	1 x 4	3x2,5	2 x 4	20	20	142	757	50
NWM 6	9.3	12.5	3x2,5	1 x 4	3x2,5	2 x 4	20	20	142	797	54
NWM 6	11	15	3x4	1 x 4	3x2,5	2 x 4	20	20	142	850	60
NWM 6	13	17.5	3x4	1 x 4	3x2,5	2 x 4	20	20	142	910	64
NWM 6	15	20	3x4	1 x 4	3x2,5	2 x 4	20	20	142	972	70
NWM 6	18.5	25	3x6	1 x 4	3x4	2 x 4	20	20	142	1005	78
NWM 6	22	30	3x6	1 x 4	3x4	2 x 4	20	20	142	1105	88
NWM 6	26.5	35	3x6	1 x 4	3x4	2 x 4	26.5	15	142	1216	98
NWM 6	30	40	3x10	1 x 5	3x4	2 x 5	26.5	15	142	1246	100
NWM 6	37	50	3x10	1 x 5	3x6	2 x 5	26.5	15	142	1346	114

Özellikler Specifications

Su ile soğutmalı sistem
Water coolant system
Su yağlamalı radyal ve eksenel tip yataklar
Water lubricated radial and axial bearings
Motor gövde borusu ve CrNi rotor milleri AISI 420 paslanmaz çeliktir
Motor housing made of stainless steel AISI 420 pipe and CrNi rotor shafts
Karbon - Seramik mekanik keçe (IP68)
Carbon - Ceramic Mechanical Seal (IP68)
Soft-Starter ile kalkışa uygun motor
Availability to be operated by Soft-Starter
NEMUTLU Motorları tekrar sarılabilmesi özelliği ile (PVC, PP ve PE2+PA bobin teli) uzun yıllar hizmet verebilir
Rewindable NEMUTLU Motors (PVC, PP & PE2+PA winding wire) provides long service life.
Motorlar su ve antifiriz karışımıyla doldurulmuştur (D.N -10 °C altı)
Motors filled with mixture of water and antifreeze (FP below -10 °C)

Teknik Özellikler Technical Specifications

Dış çap : 6" 142 mm
Outside Diameter: 6" 142 mm
Motor Güç Aralığı: 5.5 HP - 50 HP
Motor power range: 5.5 HP - 50 HP
Yol verme : Direkt ve Y/Ü.
Starting : DOL and S/Δ
Besleme gerilimi : ~3, 380 V (-%6 , +%10), 50 Hz.
Voltage : ~3, 380 V (-%6 , +%10), 50 Hz.
Çalışma ortamı sıcaklığı : Max. 30° C
Water temperature: Max. 30° C
Motor çevresinden geçen soğutma suyu hızı minimum 0.2 m/s
Around motor min. cooling water velocity 0.2 m/s
Motor Flanşı ve Mil ucu : 6" NEMA Standardı
Motor Flange and Shaft end : 6" NEMA Standard

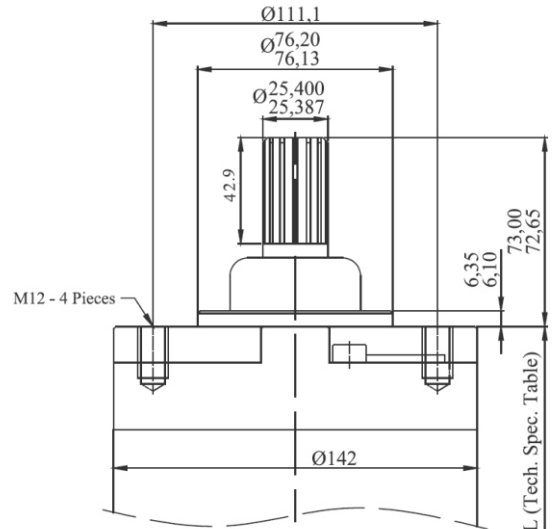

Opsiyonlar Options

Kablo boyu / **Cable Length**
Pt100 ısı sensörü / **Pt100 temperature sensor**
Sıcak su uygulamaları / **Hot water applications**
Yol verme şekli direkt veya Y/Δ / **starting DOL or S/Δ**
Malzeme inox 304-316-Dublex-Bronze
Material inox 304-316-Dublex-Bronze
Seramik - Seramik mekanik keçe (IP68)
Ceramic - Ceramic Mechanical Seal (IP68)

NWM 6" Dalgıç Motoru Performans Verileri NWM 6" Submersible Motor Performance Data

Tip Type	Güç Power		Yol Verme Starting	Frekans Frequency	Voltaj Voltage	Devir Rotation	In	IA	Verim / Efficiency			Güç Faktörü cosØ			
									% Yük / Load			% Yük / Load			
	HP	kW	Δ / S - Δ	Hz	V	rpm	A	A	50	75	100	50	75	100	
NWM 6	5.5	4	Δ / S - Δ	50	380	2800	10.2	39.4	68	70	71	0.62	0.70	0.83	
					400	2815	9.7	37.6	69	72	73	0.59	0.66	0.82	
					415	2825	9.4	36.5	69	72	73	0.58	0.65	0.81	
					60	380	3360	10.2	49.6	68	71	72	0.63	0.72	0.83
					460	3350	8.3	43.0	69	71	72	0.64	0.73	0.84	
					380	2810	13.4	51.8	71	73	75	0.63	0.71	0.83	
NWM 6	7.5	5.5	Δ / S - Δ	50	400	2825	12.8	49.7	72	74	76	0.59	0.67	0.82	
					415	2835	12.4	47.9	72	75	76	0.58	0.66	0.81	
					60	380	3365	13.6	65.0	71	73	74	0.63	0.73	0.83
					460	3360	11.1	57.3	71	73	74	0.65	0.74	0.84	
					380	2820	17.2	66.4	77	79	79	0.63	0.71	0.84	
					400	2835	16.5	63.8	79	80	80	0.59	0.67	0.82	
NWM 6	10	7.5	Δ / S - Δ	50	415	2845	16.1	62.2	79	80	80	0.58	0.66	0.81	
					60	380	3390	17.4	83.2	78	79	79	0.63	0.72	0.83
					460	3380	14.4	73.8	77	78	78	0.65	0.74	0.84	
					380	2840	21.0	81.0	79	80	80	0.63	0.71	0.84	
					400	2855	20.5	79.2	79	80	80	0.59	0.67	0.82	
					415	2865	19.8	76.7	80	81	81	0.58	0.66	0.81	
NWM 6	12.5	9.3	Δ / S - Δ	50	380	3400	21.3	102	79	80	80	0.63	0.73	0.83	
					460	3395	17.6	91	78	79	79	0.65	0.74	0.84	
					380	2840	24.3	93.9	80	81	81	0.63	0.72	0.85	
					400	2855	23.3	90.1	81	82	82	0.60	0.68	0.83	
					415	2865	22.8	88.1	81	82	82	0.58	0.67	0.82	
					60	380	3410	24.9	119	79	79	80	0.64	0.74	0.84
NWM 6	15	11	Δ / S - Δ	50	460	3400	20.6	107	79	80	80	0.66	0.75	0.84	
					380	2850	28.7	111	80	81	81	0.64	0.72	0.85	
					400	2865	27.6	107	81	82	82	0.61	0.69	0.83	
					415	2875	27.0	105	81	82	82	0.59	0.67	0.82	
					60	380	3425	29.1	139	80	81	81	0.64	0.74	0.84
					460	3415	23.7	123	80	81	81	0.66	0.75	0.85	
NWM 6	17.5	13	Δ / S - Δ	50	380	2870	33.1	128	80	81	81	0.64	0.73	0.85	
					400	2875	31.8	123	81	81	82	0.61	0.69	0.83	
					415	2885	31.1	120	81	82	82	0.59	0.67	0.82	
					60	380	3440	33.6	161	80	80	81	0.64	0.73	0.84
					460	3440	27.4	142	80	80	81	0.66	0.75	0.85	
					380	2870	40.9	158	81	81	82	0.64	0.72	0.84	
NWM 6	20	15	Δ / S - Δ	50	400	2885	39.8	154	81	82	82	0.60	0.68	0.82	
					415	2895	38.8	150	81	82	82	0.58	0.66	0.81	
					60	380	3460	41.3	198	80	80	81	0.63	0.72	0.84
					460	3450	33.8	174	80	80	81	0.65	0.74	0.85	
					380	2875	48.1	186	82	83	83	0.64	0.72	0.84	
					400	2890	46.7	181	82	83	83	0.60	0.68	0.82	
NWM 6	25	18.5	Δ / S - Δ	50	415	2895	45.6	176	82	83	83	0.58	0.66	0.81	
					60	380	3475	48.6	245	81	81	82	0.64	0.73	0.84
					460	3465	39.7	205	81	81	82	0.65	0.74	0.85	
					380	2880	56.5	218	83	84	84	0.65	0.73	0.85	
					400	2895	54.9	212	83	84	84	0.61	0.69	0.83	
					415	2905	53.5	207	83	84	84	0.59	0.67	0.82	
NWM 6	30	22	Δ / S - Δ	50	60	380	3480	57.2	290	81	82	83	0.64	0.74	0.85
					460	3470	46.7	241	81	82	83	0.66	0.75	0.86	
					380	2890	63.9	247	83	84	84	0.65	0.73	0.85	
					400	2905	62.2	240	83	84	84	0.61	0.69	0.83	
					415	2915	60.7	234	83	84	84	0.59	0.67	0.82	
					60	380	3490	64.7	330	82	83	83	0.64	0.74	0.85
NWM 6	35	26.5	Δ / S - Δ	50	460	3480	52.8	272	82	83	83	0.66	0.75	0.86	
					380	2900	79.7	308	82	83	83	0.65	0.73	0.85	
					400	2915	76.7	297	82	83	83	0.61	0.69	0.84	
					415	2925	74.8	289	83	84	83	0.59	0.67	0.83	
					60	380	3495	78.8	400	83	84	83	0.64	0.74	0.85
					460	3490	64.3	332	83	84	83	0.66	0.75	0.86	



Motor Yedek Parça Özellikler Motor Spare Parts Specifications

أجزاء المحرك الميزات

أغیر işletme şartlarına uygun, yüksek kapasiteli eksenel yatak seti

Her iki yöne de dönebilme kabiliyeti sağlar, yüksek yük taşıma kapasitesine sahiptir.

Heavy duty bearings with high thrust capacity

Heavy duty bearings provides the option to revolve both sides, has the capacity to carry high thrust load.

محامل الوزن الثقيل ذات مقدرة الدفع العالية

تؤمن محامل الوزن الثقيل خيار الدوران في كلا الاتجاهين، ولها مقدرة حمل الأحمال ذات الدفع العالي.

Su ile yağlamalı radyal yataklar

Yapısında bulunan kanallar vasıtasıyla su ile rahatça yağlanan karbon yataklar, rotor milini alt ve üstte hassas olarak yataklar.

Water lubricated radial carbon bearings

Radial carbon bearings, which have channels in its structure that makes it possible to get lubricated by water easily, provides precise bearing of rotor shaft at up and down.

محامل الكربون الشعاعية

محامل الكربون الشعاعية، التي تحتوي على قنوات في بنيتها تجعل من الممكن غمرها بالماء بسهولة، وتؤمن تحمل عالي لدوران المحرك نحو الأعلى والأسفل.

Krom kaplamalı mil burcu

Radyal yatakların çalıştığı bölgede bulunan ve krom ile kaplanmış ve hassas olarak taşlanmış mil burçları rotorun yataklanmasında büyük önem taşır.

Chrome-plated bearing collet

Chrome-plated and precisely machined bearing collets which are located in the radial bearings operating area, have great importance for bearing the rotor.

حامل الطوق المعدني المطلب بالكروم

الأطواق المعدنية المطلبة بالكروم والمشكلة بدقة والتي توضع في منطقة تشغيل المحامل الشعاعية، لها أهمية كبيرة في محامل الدوران.

Mekanik salmastra sistemi ile kuma karşı yüksek direnç (IP68 koruma sınıfı)

Diğer bir çok markada opsiyonel sunulurken watermot motorlarında standart olan mekanik salmastra, motor içerisine kum ve diğer partiküllerin girişini engeller. Yatakların uzun ömürlü olmasını sağlar.

Mechanical sealing system for high sand resistance and degree of protection: IP68

Although mechanical seal is optionally used by other companies, it is always used by watermot as a stand ard, to prevent sand and other particles to get in motors to provide long bearing life.

نظام التغليف الآلي لمقاومة الرمال العالية ودرجة حماية تصل إلى IP68

رغم أن التغليف الآلي يستخدم من قبل الشركات الأخرى اختياريًا، فإنه يستخدم دائمًا من قبل watermot كمعيار، لمنع الرمال والجزيئات الأخرى من الدخول في المحركات لتأمين عمر محامل أطول.

Pratik ve kolay montajlı enerji kablosu çıkışı

Enerji kablosunun gövdeye bağlantısı kablo lastiği ve sacı ile pratik olarak sağlanır. Herhangi bir hasar vermeden kolay bir şekilde enerji kablosunu değiştirebilirsiniz.

Practical and easy-to-mount output power cable

Connection of the power cable to body is made practically by cable seal and seal cover. Power cables can be changed easily without any damage.

كابل طاقة ناتجة عملي وسهل التركيب

اتصال كابل الطاقة مع الجسم يتم بشكل عملي بواسطة تغليف الكابل وغطاء التغليف. يمكن تبديل كابلات الطاقة بسهولة دون أي ضرر.

Basınç dengeleyici çekvalf

Yüksek kaliteli çekvalfi, motordaki basınç değişimlerini mükemmel kontrol eder. Basınç arttığında dışarıya su atarak, basınç düştüğünde ise kuyu suyunu filtre edip içeri alarak iç basıncı dengeler. Bu sayede membranın basınçtan kaynaklı patlamasını engeller.

Pressure balancing checkvalve

Pressure balancing checkvalve controls the pressure changes inside the motor. When the pressure increases, it throw water out of the motor. When the pressure drops, it filtrates the water inside well and gets it inside the motor by the help of this checkvalve to balance the pressure inside. That's why pressure differences inside motor never causes membrane under motor to blow up.

صمامات فحص توازن الضغط

يتحكم صمام فحص توازن الضغط بتغيرات الضغط داخل المحرك. عندما يتزايد الضغط، يقوم بطرح الماء خارج المحرك. وعندما يتناقص الضغط، ينقي الماء داخل البئر ويدخله إلى المحرك بمساعدة صمام الفحص ليوازن الضغط في الداخل. لهذا فإن تغيرات الضغط داخل المحرك لا تتسبب بانفجار الغشاء تحت المحرك.

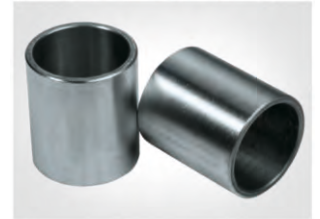

Motor Yedek Parça Özellikler Motor Spare Parts Specifications

أجزاء المحرك الميزات



PT100 sıcaklık sensörü ile aşırı ısınmaya karşı koruma

Üst yatakta standart olarak bulunan yuvaya PT100 termal sensörleri rahatlıkla bağlanarak motor sıcaklık değerleri kontrol altında tutulabilir.

PT100 Overheating protection

By connecting the PT100 thermal sensors to the slot that is standardly placed on upper bearing body, motor temperature values can be easily measured.

حماية من الحرارة الزائدة تصل إلى 100 PT

بوصل حساسات الـ 100 PT مع الفتحة التي تم وضعها بطريقة معيارية على جسم الحامل العلوي يمكننا قياس قيم درجة حرارة المحرك بسهولة.



Up-Thrust rondelası

Taşlanmış yüzeyi ve üzerinde bulunan su kanalları sayesinde Up-Thrust yüklerini bertaraf ederek motorun güvenli çalışmasını sağlar.

Up-Thrust ring

Provides safe operation conditions for motor by absorbing Up-Thrust loads with its machined surface and water channels on it.

حلقة الدفع العلوي

يؤمن ظروف عمل آمنة للمحرك بواسطة امتصاص أحمال الدفع العلوية بسطحه الذي تم تشكيله و قنوات الماء الموجودة عليه.



Kablo bağlantısı

Özel olarak dizayn edilmiş kablo pabucu, motor içinde bulunan suyun, kablo içinden ilerleyerek enerji kablosunun ek yerlerine ulaşmasını önler.

Cable connection

Preventing the water inside the motor to run through the cable and reach connection parts of power cables by specially designed cable seals.

وصلة الكابل

تمنع الماء في داخل المحرك من الجريان عبر الكابل أو الوصول إلى أجزاء الوصل في كابلات الطاقة بواسطة سدادات خاصة التصميم للكابل.



Ayar somunu

Eksenel yatak gövdesi üzerinde bulunan ince dişli ayar somunu ile standart mil yüksekliği hassas olarak ayarlanabilir.

Adjustment screw

Standard shaft height can be precisely adjusted by the adjustment screw on the thrust bearing base.

برغي الضبط

يمكن ضبط ارتفاع عمود المحرك المعياري بواسطة برغي الضبط على قاعدة حامل الدفع.



Membran

Membran, motor içindeki soğutma suyunun ısınmasından doğan genleşme basıncını minimize eder.

Membrane

Membrane minimizes the expansion pressure that is caused by heating of cooling water's inside the motor

الغشاء

يقلل الغشاء من توسع الضغط الحاصل بسبب مياه التسخين أو التبريد داخل المحرك.

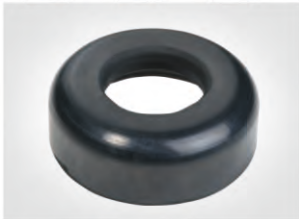

Kum sıçratma lastiği

Kum sıçratma lastiği, kuyu suyu içinde bulunan kumun mekanik salmastraya, oradan da motor içine girmesini engellemeye yardımcı olur.

Slinger (sand guard)

Slinger helps to prevent the sand inside the water of the well entering in mechanical seal and through mechanical seal to inside of the motor.

الإطار (الحامي من الرمال)

يساعد الإطار على منع دخول الرمال الموجودة في مياه الآبار إلى الغلاف الميكانيكي و عبر الغلاف الميكانيكي إلى المحرك.